

MP-11



The MP-11 is used to provide gauge pressure sensors with an ambient reference that has no moisture/humidity that can cause errors and/or sensor failure. Once connected to the reference tube of a pressure sensor the MP-11 allows for a change in barometric pressure with very little error. The advantage of the MP-11 is zero maintenance. There are no filters or desiccant to check or change.

Installation instructions:

1. Install the pressure sensor protecting the reference tube with the installed shipping cover.
2. Mount the MP-11 (when installed outside mount vertically as shown above) within approximately 2 feet of the sensors reference tube.
3. Remove the sensor shipping cover and the shipping cap from the MP-11.
4. Attach the supplied tubing to both the sensor reference tube and the port on the MP-11. (shorten the tubing if necessary)
5. The installation is complete. The only maintenance necessary is to occasionally check the tubing is connected, and not kinked or cracked.

NOTE: DO NOT blow into the MP-11. This will induce moisture, which could be harmful to the pressure sensor. The MP-11 has been purged and filled with dry nitrogen.

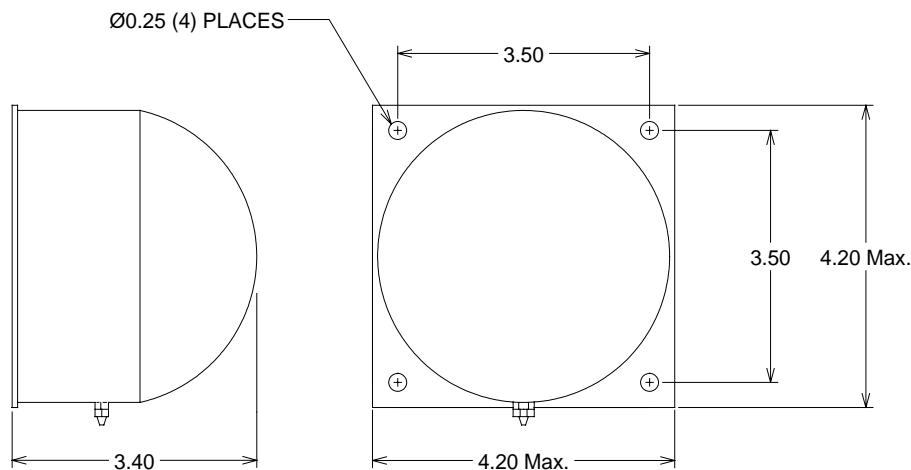

DEVAR Inc.

706 Bostwick Avenue, Bridgeport, CT 06605-2396
TEL: 203-368-6751 FAX: 203-368-3747
www.devarinc.com 1-800-566-6822